

# The Real World: Redesigning a Welding Class to Match Industry Practices

## Introduction

- Many programs use outdated methods that don't prepare students for modern fabrication.
- Partnership model (Wells et al., 2021) stresses aligning instruction with industry practices.
- Traditional welding = isolated tasks; redesign used project-based, shop-style approach.
- Students gained real-world mass production experience in class.



## How it Works

- Fabricated real products: takedown grills, rocket stoves, fire pits.
- Designs adjusted for CNC sheet sizes to reduce waste and fit equipment.
- Six student teams managed subassemblies in a production-line style.
- Industry partner donated steel and provided design feedback.
- Students practiced with welding coupons before final builds.



## Costs

- ~\$21,000 in steel donated by industry partner.
- 10,000 welding coupons provided for practice.
- Wire, gas, and consumables covered by university inventory.
- CNC nesting and standardized designs reduced waste and costs.
- Model sustained by donations, new partnerships, grants, and showcases.

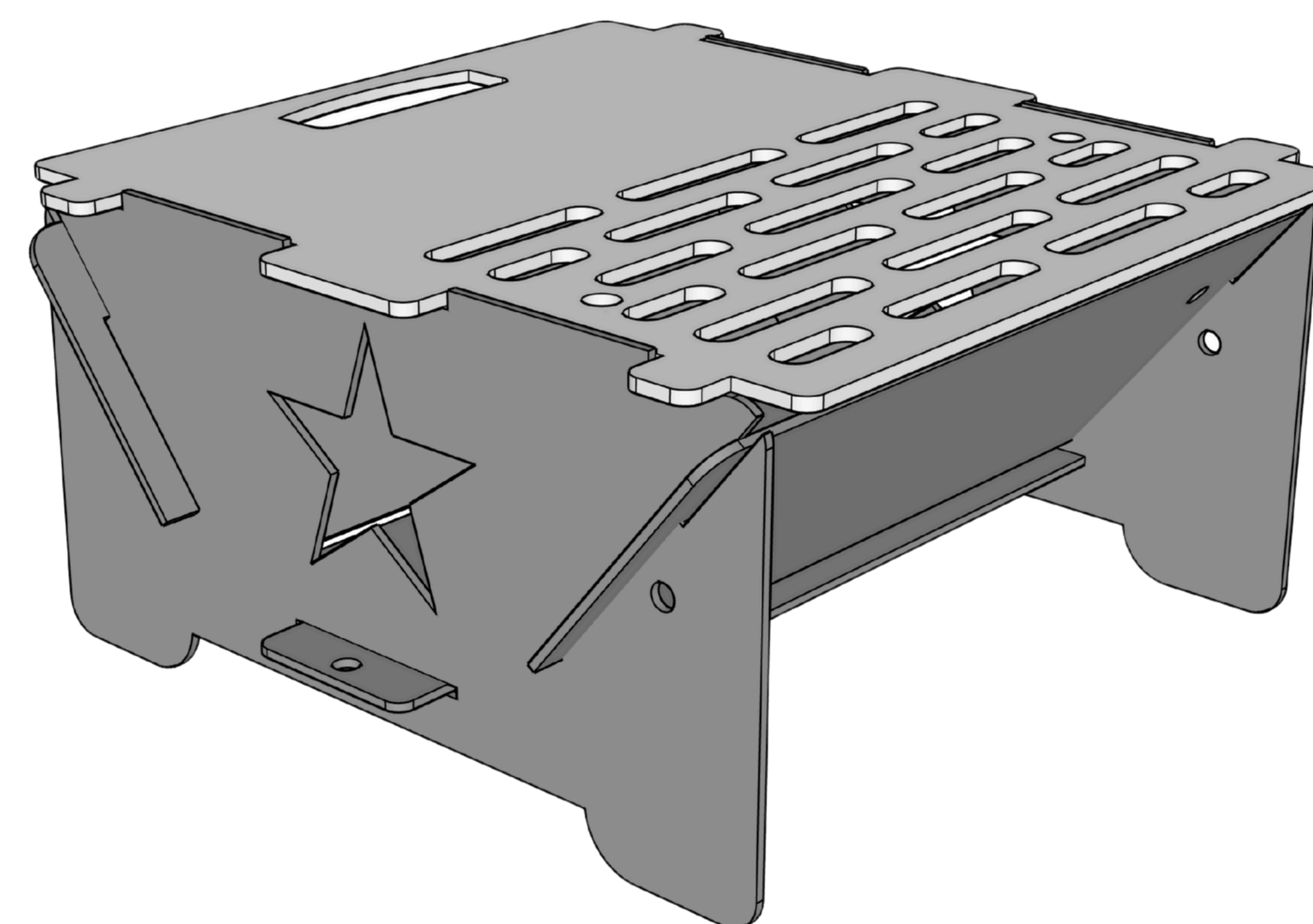

## Results to Date

- 57 total products completed: 45 grills, 6 stoves, 6 fire pits.
- Students rotated through prepping, welding, grinding, painting, and quality checks.
- CNC nesting minimized material waste.
- Welding coupons boosted skill confidence and reduced errors.
- Students built efficiency, teamwork, and workplace problem-solving skills.
- Industry feedback reinforced professional standards.



## Future Plans

- Add cost estimation lessons and capstone-style design/build projects.
- Expand product designs (e.g., hibachi-style griddle).
- Strengthen industry partnerships with internships and sponsorships.
- Host community showcases for students to present and sell work.
- Enhance client communication and real-world readiness.